

 <b>Government eProcurement System</b>		<b>eProcurement System Government of India</b>							
		<b>Tender Details</b>							
		Date : 20-Sep-2024 04:11 PM							
		 <a href="#">Print</a>							
<b>Basic Details</b>									
<b>Organisation Chain</b>	Department of Agricultural Research and Education  Indian Council of Agricultural Research,DoARE,MoA  CIARI-Port Blair - DoARE								
<b>Tender Reference Number</b>	57(449)/2024-2025/Estate								
<b>Tender ID</b>	2024_DARE_827004_1	<b>Withdrawal Allowed</b>	Yes						
<b>Tender Type</b>	Open Tender	<b>Form of contract</b>	Works						
<b>Tender Category</b>	Works	<b>No. of Covers</b>	2						
<b>General Technical Evaluation Allowed</b>	No	<b>ItemWise Technical Evaluation Allowed</b>	No						
<b>Payment Mode</b>	Offline	<b>Is Multi Currency Allowed For BOQ</b>	No						
<b>Is Multi Currency Allowed For Fee</b>	No	<b>Allow Two Stage Bidding</b>	No						
<b>Payment Instruments</b>			<b>Cover Details, No. Of Covers - 2</b>						
<b>Offline</b>	<b>S.No</b>	<b>Instrument Type</b>	<b>Cover No</b>	<b>Cover</b>	<b>Document Type</b>	<b>Description</b>			
	1	Bank Guarantee	1	Technical Bid	.pdf	Technical Bid			
	2	Demand Draft	2	Financial Bid	.xls	Financial Bid			
	3	FDR							
<b>Tender Fee Details, [Total Fee in ₹ * - 0.00]</b>				<b>EMD Fee Details</b>					
<b>Tender Fee in ₹</b>	0.00	<b>Fee Payable To</b>	Nil	<b>Fee Payable At</b>	Nil	<b>EMD Amount in ₹</b>	29,300	<b>EMD Exemption Allowed</b>	Yes
<b>Tender Fee Exemption Allowed</b>	No					<b>EMD Fee Type</b>	fixed	<b>EMD Percentage</b>	NA
						<b>EMD Payable To</b>	The Director ICAR Unit CARI Port Blair	<b>EMD Payable At</b>	Garacharma
<a href="#">Click to view modification history</a>									
<b>Work /Item(s)</b>									
<b>Title</b>	Construction of Polyhouse								
<b>Work Description</b>	Construction of Polyhouse with 04 nos. of platform near playground at Garacharma Farm.								
<b>Pre Qualification Details</b>	Please refer Tender documents.								
<b>Independent External Monitor/Remarks</b>	NA								
<b>Show Tender Value in Public Domain</b>	Yes								
<b>Tender Value in ₹</b>	14,69,224	<b>Product Category</b>	Construction Works	<b>Sub category</b>	NA				
<b>Contract Type</b>	Tender	<b>Bid Validity(Days)</b>	180	<b>Period Of Work (Days)</b>	30				
<b>Location</b>	ICAR-CIARI, Garacharma, Port	<b>Pincode</b>	744105	<b>Pre Bid Meeting Place</b>	NA				

 <b>Government of India</b> <b>eProcurement System</b>	Blair				
<b>Pre Bid Meeting Address</b>	NA	<b>Pre Bid Meeting Date</b>	NA	<b>Bid Opening Place</b>	ICAR-CIARI, Garacharma, Port Blair
<b>Should Allow NDA Tender</b>	No	<b>Allow Preferential Bidder</b>	No		

**Critical Dates**

<b>Publish Date</b>	20-Sep-2024 04:30 PM	<b>Bid Opening Date</b>	11-Oct-2024 03:00 PM
<b>Document Download / Sale Start Date</b>	20-Sep-2024 05:00 PM	<b>Document Download / Sale End Date</b>	10-Oct-2024 03:00 PM
<b>Clarification Start Date</b>	NA	<b>Clarification End Date</b>	NA
<b>Bid Submission Start Date</b>	20-Sep-2024 05:00 PM	<b>Bid Submission End Date</b>	10-Oct-2024 03:00 PM

**Tender Documents**

NIT Document	S.No	Document Name	Description	Document Size (in KB)
		1	Tendernotice_1.pdf	NOTICE INVITING TENDER

Work Item Documents	S.No	Document Type	Document Name	Description	Document Size (in KB)
		1	Tender Documents	TENDERDOCUMENTFINAL.pdf	TENDER DOCUMENT
	2	BOQ	BOQ_869048.xls	BILLING OF QUANTITIES	302.00
	3	Additional Documents	DRAWINGS.pdf	DRAWING AND DESIGN	1101.82

**Bid Openers List**

S.No	Bid Opener Login Id	Bid Opener Name	Certificate Name
1.	d.karunakaran@icar.gov.in	DHANASEKAR KARUNAKARAN	D KARUNAKARAN
2.	shriravibabu123@gmail.com	Ravi Babu	RAVI BABU
3.	karuppaiahchitra@gmail.com	Karuppaiah p	KARUPPAIAH
4.	sridhambiswas@gmail.com	S K Biswas	SRIDHAM KUMAR BISWAS

**Tender Properties**

<b>Auto Tendering Process allowed</b>	No	<b>Show Technical bid status</b>	Yes
<b>Show Finance bid status</b>	Yes	<b>Stage to disclose Bid Details in Public Domain</b>	Technical Bid Opening
<b>BoQ Comparative Chart model</b>	Normal	<b>BoQ Comparative chart decimal places</b>	2
<b>BoQ Comparative Chart Rank Type</b>	L	<b>Form Based BoQ</b>	No

**TIA Undertaking**

S.No	Undertaking to Order	Tender complying with Order	Reason for non compliance of Order
1	<a href="#">PPP-MII Order 2017</a>	Agree	
2	<a href="#">MSEs Order 2012</a>	Agree	

**Tender Inviting Authority**

<b>Name</b>	The Director, ICAR-CIARI, Port Blair
<b>Address</b>	ICAR-CIARI, Garacharma, Port Blair

**Tender Creator Details**

<b>Created By</b>	C Siji
<b>Designation</b>	UDC

Created Date 20-Sep-2024 03:37 PM



Government  
eProcurement  
System



**ICAR - CENTRAL ISLAND AGRICULTURAL RESEARCH INSTITUTE**

Bathu Basti, Garacharma P.O, Port Blair - 744 105

ANDAMAN AND NICOBAR ISLANDS, INDIA

Tel: 03192 – 250235; Fax: 03192 – 251068

E-mail: [hoa.ciari@icar.gov.in](mailto:hoa.ciari@icar.gov.in), [director.ciari@icar.gov.in](mailto:director.ciari@icar.gov.in)

Website: <https://ciari.icar.gov.in>



F.No. 57(449)/2024-2025/Estate/

Date: 20.09.2024

**STANDARD ONLINE (E-PROCUREMENT MODE) BIDDING DOCUMENTS  
FOR CONSTRUCTION OF A POLYHOUSE NEAR PLAYGROUND AT  
GARACHARMA FARM.**

**Document to be submitted online  
as per Schedule of requirement**

**NOTICE INVITING ONLINE TENDER**

The Director, ICAR-CIARI, Port Blair, invites e-tenders through the website URL: <http://eprocure.gov.in/eprocure/app> under two bid systems from eligible and qualified bidders for construction of a polyhouse near playground at Garacharma Farm.

**CRITICAL DATE SHEET**

Tender ID (To be allotted by portal after uploading of tender)	
Tender Reference No	File No. 57(449)/2024-2025/Estate/, Dated: 20.09.2024
Date of release of Tender through e-procurement Portal	20.09.2024 at 04:00 PM
Bid Submission Start Date (Online)	20.09.2024 at 05:00 PM
Last date for Receipt of EMD at ICAR-CIARI, Port Blair	10.10.2024 at 03.00 PM
Last Date & time for submission of online Bid	10.10.2024 at 03.00 PM
Date & time for opening of Bid	11.10.2024 at 10.00 AM
Address for Communication	The Director, ICAR-CIARI, Garacharma, Port Blair-744105

*Kamiehk*  
20/9/24  
**Administrative Officer**  
प्रशासनिक अधिकारी  
भा.कृ.अनु.प.-के.डी.कृ.अनु.सं. पोर्ट ब्लेयर  
Administrative Officer  
ICAR-CIARI, Port Blair



# ICAR - CENTRAL ISLAND AGRICULTURAL RESEARCH INSTITUTE

Bathu Basti, Garacharma P.O, Port Blair - 744 105

ANDAMAN AND NICOBAR ISLANDS, INDIA

Tel: 03192 – 250235; Fax: 03192 – 251068

E-mail: [hoa.ciari@icar.gov.in](mailto:hoa.ciari@icar.gov.in), [director.ciari@icar.gov.in](mailto:director.ciari@icar.gov.in)

Website: <https://ciari.icar.gov.in>



F. No. 57(449)/2024-2025/Estate/

Date: 20.09.2024

## **COMPETITIVE BIDDING TENDER DOCUMENT**

**Name of the work:** Construction of Polyhouse with 04 nos. of platform near playground at Garacharma Farm.

**Size of Polyhouse:** 10m (L) x 10m (B) x 2.6m (H)

### **General Terms & Conditions:-**

1. The tender should be accompanied with Earnest Money Deposit (EMD) of **Rs. 29,300/- (Rupees twenty nine thousand three hundred only)** payable through Demand Draft/FDR in favour of the Director, ICAR Unit: CARI, Port Blair. Tenders without EMD will be treated as cancelled.
2. The L1 firm / bidder fulfilling the qualification of past performance, experience, technical competence, financial strength to handle the work successfully will be selected for award of the contract [(Based on technical bid document Annexure I (A)]. However, the Institute shall have the right to relax general construction experience particular available bid capacity for the utmost importance to develop new contractors and to provide avenues to Sub-Contractors.
3. Work shall be carried out as per the instruction, direction and satisfaction & supervision of Incharge Estate Section as per the approved plan/structure of Polyhouse.
4. The sketch of the proposed Polyhouse is uploaded with the tender document in order to have an idea before quoting the rate.
5. The rate includes all labours, materials, transportation, tools and tackles etc. as required for completing the work.
6. The work should be started within **10 (Ten)** days from the date of issue of work order failing which the work order shall be treated as cancelled and Performance Guarantee/EMD shall be forfeited on the recommendation by the In-charge, Estate Section.
7. The rate may be quoted after inspection of site and clarification of all details from In-charge, Estate Section.
8. The work should be completed within **30 (Thirty Days)** days from the date of issue of work order failing which the work order may be cancelled. Extension of time may be granted to the contractor beyond agreed time of completion of the work under force majeure condition. In case the contractor fails to complete the work within the stipulated/ extended period of time, liquidated

damages shall be levied from to the contractors @ 0.50% per week, maximum of 10% of the total value of the contract.

9. The Institute will not accept any delay caused by the Contractor due to non-availability of materials or any other local issues etc. Except under natural calamities. The progress of work should be in proportion to the time allocation financially and item wise.
10. The Director shall have the liberty to postpone or not to execute any item of work and the contractor shall not be entitled to any compensation for non - execution of such items of work.
11. During execution no change shall be made by the contractor in the approved drawing & design and specifications of the items at site without the consent of In-charge Estate Section.
12. In case of dis-satisfactory work the contract may be terminated at any time and in such case the EMD/ Security deposit shall be forfeited.
13. In case the contractor fails to complete the work within the stipulated/ extended period of time and according to our satisfaction, the Director, CIARI shall have the right to terminate the contract and get the work done through any other firm or agency. In such case the EMD/ Security deposit of the contractor shall be forfeited.
14. The water as required for construction and curing shall be arranged by the contractor for which no extra payment shall be made.
15. All the materials purchased for construction work by the contractor shall be as per the CPWD/ ISI/ BIS Standards/ specification and got approved by the Incharge Estate Section. In case, if they fails to get approved items or fixed substandard item, it shall not be considered for payments.
16. The contractor shall not be provided any store for storing of the construction materials and their tools. However, a site will be given temporarily to construct a store in CIARI Complex. The store should be dismantled immediately after handing over the structure/ buildings to the Institute failing which the bill will not be processed for release of payment.
17. Quantity of work may be increased or decreased according to the actual need of work and hence deviation of work shall be undertaken as per quoted rate without asking any compensation.
18. All the materials particularly cement, steel aggregate, etc. wherever required have to be stocked at site as per the instructions of the Engineer Incharge of the Section before commencement of work. The Firm may submit a copy of the bills of above items to the Engineer Incharge whenever demanded. In case, the contractor fails to stock the materials and produce the bills, their work bill may not be verified for payment.
19. When the construction work is going on, the contractor has to depute an experienced site engineer/supervisor or he himself has to be present at work site everyday till the work is completed on that day and has to inform the I/c Estate Section every day in advance over phone or through any other means about the work program. In case the contractor fails to comply with the above, the work carried out on that day will not be considered for payment.

20. The contractor has to deposit **3%** of the tender value of the contract through Bank Guarantee / Demand draft / Fixed deposit towards proper performance of the contract after acceptance of tender and the same shall be kept as security deposit and may be released after **01 (One year)** of successful completion of work and will be treated as guarantee for successful performance of completed works.
21. An amount equal to 10% of value of work completed (inclusive of 3% performance guarantee) shall be deducted from the bill of the contractor as security deposit and shall be release after 01 year of successful completion of work.
22. The contractor has to pay minimum wages as per the rate of Government to their labour force engaged for tendered work.
23. The standard deduction such as Income tax, GST and other fares / rates etc. imposed by the Government time to time shall be deducted from the bill of the contractor.
24. After completion of the work within 1 year, if any defect, or damage or poor workmanship is noticed, the same shall be rectified by the contractor, within 10 days failing which the Security deposit shall be forfeited.
25. The Director, CIARI, Port Blair reserves the right to accept or reject any or all the tenders without assigning any reason thereof and the decision of the Director, CIARI, Port Blair shall be final and binding to all concerned parties.
26. The Director, CIARI, Port Blair shall be the sole arbitrator for all disputes between the contractor and Institute. The decision of the Director shall be final and binding to the both the parties. All disputes shall be subject to the jurisdiction at Port Blair.

Signature of the Contractor  
Name of the firm:  
Address of the firm:  
Mobile No./Telephone No.:

*Kamishk*  
*20/11/24*  
**Administrative Officer**  
प्रशासनिक अधिकारी  
भा.कृ.अनु.प.-के.डी.कृ.अनु.सं. पोर्ट ब्लेयर  
Administrative Officer  
ICAR-CIARI, Port Blair

**INSTRUCTIONS FOR ONLINE BID SUBMISSION**

1. For Online Bid Submission as per the directives of Department of Expenditure, this tender document has been published on the Central Public Procurement Portal (URL:https://eprocure.gov.in/eprocure/app). The bidders are required to submit copies of their bids electronically on the CPP Portal, using valid Digital Signature Certificates. More information useful for submitting the online bids on the CPP Portal is available/obtained at URL:https://eprocure.gov.in/eprocure/app. Manual/offline bids shall not be accepted under any circumstances.

**For Registration**

1. Bidders are required to enroll on the e-Procurement module of the Central Public Procurement Portal (URL:https://eprocure.gov.in/eprocure/app) by clicking on the link "Click here to Enroll". Enrolment on the CPP Portal is free of charge.
2. While submitting the tender, if any of the prescribed conditions are not fulfilled or are incomplete in any form, the tender is liable to be rejected. If any tenderer stipulate any condition of his own, such conditional tender is liable to be rejected.
3. All the tender documents & price bid to be uploaded as per this tender are to be digitally signed by the bidder.
4. All the communications with respect to the tender shall be addressed to: The Director, ICAR-CIARI, Garacharma, Port Blair-744105.
5. The firms are also required to upload copies of the following documents failing which the quotation will not be considered:-

**DOCUMENTS TO BE UPLOADED IN COVER-I**

**(A) TECHNICAL BID**

- a. Scanned copy of EMD / its exemption, if any.
- b. Scanned copy of Firms registration, Enlistment Certificate/Order, Experience certificates of similar nature of works, PAN Card, GSTIN.
- c. Scanned copy of Bank Account Details duly filled in Annexure-III
- d. Tender Acceptance letter (Annexure-IV)
- e. Scanned copy of Annexure-V duly filling column No. 04.
- f. Valid registration with employees provident fund organization under EPF and miscellaneous provision Act, 1952.
- g. Annual Audited turnover for 03 (Three) Years.

**(B) FINANCIAL BID / BOQ - II**

- a. Price Bid as BoQ\_XXXX.xls to be filled online and submitted. Please note that the file name should not be changed.

*Kamlesh*  
*20/9/24*  
**Administrative Officer**  
प्रशासनिक अधिकारी  
भा.कृ.अनु.प.-के.डी.कृ.अनु.सं. पोर्ट ब्लेयर  
Administrative Officer  
ICAR-CIARI, Port Blair



**TERMS AND CONDITIONS FOR BIDDERS**

- 1) The bidders may submit duly filled and completed bidding document ONLINE as per instruction contained in Annexure -I. Incomplete bid shall be rejected. The conditions of tender shall be governed by the details contained in complete bid document.
- 2) Bidders shall select the payment option as offline to pay the EMD.
- 3) Price once quoted will be final and no further negotiation/alteration will be made thereafter.
- 4) The rates should be quoted as per the BOQ uploaded on the CPP Portal. The bidders are advised to download this BOQ\_XXX.xls as it is and quote their offer/rates in the permitted column and upload the same in the Financial Bid. The Bidder shall not tamper / modify downloaded price bid template in any manner. In case if the same is found to be tampered / modified in any manner, tender will be completely rejected and EMD would be forfeited and tenderer is liable to be banned from doing business with ICAR-CIARI.
- 5) In case, holiday is declared by the Government on the day of opening the bids of the tender or it happened to be non-working day due to Bandh / Strike or any other reasons, the tender will be opened on the next working day at the same time.
- 6) Bid Validity: 180 days.
- 7) The detailed instruction for online submissions of bid(s) through e-procurement module of Central Public Procurement of NIC, the bidder(s) may visit following link: [https://eprocure.gov.in/eprocure/apppage=HelpForContractors & service=page](https://eprocure.gov.in/eprocure/apppage=HelpForContractors&service=page)
- 8) The Successful Bidder irrespective of registration status will have to deposit the Performance Security @ 3% (in Rs.) of the contract value in shape of Demand Draft/FDR drawn in any Nationalized Bank in favour of "ICAR UNIT-CARI" payable at SBI, Garacharma (Code No.SBIN0009670), Port Blair.
- 9) Dispute resolution: Decision of Director of the Institute shall be final for any aspect of the contract and binding to all parties. Disputes arising, if any on the contract will be settled at his/her level by mutual consultation and in case of failure of settlement dispute shall be referred to the sole arbitrator to be appointed by the Director, ICAR-CIARI, Port Blair. The decision of the sole Arbitrator so appointed shall be final and binding on the parties. Arbitration proceedings shall be governed by the Arbitration & Constitution Act, 1996. The seat of Arbitration will be Port Blair and language will be English. Laws of India in force will be applicable.
- 10) The payment may be released within 30 days from the date of satisfactory completion of work. No advance payment will be made under any circumstances.

*Kamishk*  
*20/9/24*

**Administrative Officer**

प्रशासनिक अधिकारी  
भा.कृ.अनु.प.-के.डी.कृ.अनु.सं. पोर्ट ब्लेयर  
Administrative Officer  
ICAR-CIARI, Port Blair

**MANDATE FORM FOR BANKING DETAILS**

Registered /Postal Address:

1	Permanent Account Number (PAN) No.		
2	Name of Account Holder		
3	Bank details:		
	A	Bank Name	
	B	Branch Address	
	C	Account No.	
	D	Type of Account (Current/Savings)	
	E	MICR No	
	F	IFSC Code	

**Signature of Bidder,  
with official seal**

**TENDER ACCEPTANCE LETTER**  
(to be given on Company letter head)

Date:

To,

The Director,  
ICAR-CIARI,  
Garacharma,  
Port Blair-744105

Sub: Acceptance of terms and Conditions of tender.

Tender Reference No:

Name of the tender/work:-

---

---

Dear Sir,

1. I/we have downloaded the tender documents for the above mentioned /work from the website (s) namely CPPP & CIARI Website:

---

as per your advertisement,, given in the above mentioned website(s).

2. I/we hereby certify that I/we have read the entire terms and conditions of the tender documents from Page No. \_\_\_\_\_ to \_\_\_\_\_ (including all documents like annexure(s), schedules(s), etc.,) which form part of the contract agreement and I/we shall abide hereby the terms/ conditions/clauses contained therein.
3. The corrigendum(s) issued from time to time by your department / organization too have also been taken into consideration, while submitting this acceptance letter.
4. I/we hereby unconditionally accept the tender conditions of above mentioned tender document (s)/corrigendum(s) in its totality /entirety.
5. I/we do hereby declare that our Firm has not been blacklisted/debarred by any Govt. Department/Public Sector Undertaking.
6. I/we certify that all information furnished by our Firm is true and correct and in case if any information is found to be incorrect/untrue or found violated, then your department/organization shall without giving any notice or reason thereof or summarily reject the bid or terminate the contract, without prejudice to any other rights or remedy including the forfeiture of the full said earnest money deposit absolutely.

Yours faithfully,

(Signature of the Bidder, with Official Seal)

**TECHNICAL BID**

**Name of the Firm :**  
**Tender Reference No :**  
**Name of the Tender/work :**

**Check List**

<b>Sl. No</b>	<b>Details</b>	<b>Submitted (Yes/No)</b>	<b>If submitted , mention page no. of pdf file</b>	<b>Remarks</b>
1.	Scanned copy of Earnest Money Deposit ( EMD)/its exemption, if any			
2.	Scanned copy of Firms registration, Enlistment certificate/order, PAN Card, GSTIN.			
3.	Tender Acceptance letter (Annexure-IV)			
4.	Work experience certificates of similar work			
5.	Scanned copy of Income Tax Statement for the last (03) three years.			
6.	Scanned copy of Bank details (Annexure-III).			
7.	Scanned copy of Annexure-V duly filling column No. 04			
8.	Valid registration with Employee Provident Fund Organization under EPF and miscellaneous provision Act, 1952.			
9.	Annual audited turnover for the last 03 (Three) years			

**Signature of the Bidder,  
with Official Seal**

**Bidders guidance for Online Bid Submission**

As per the directives of Department of Expenditure, this tender document has been published on the Central Public Procurement Portal (URL: <http://eprocure.gov.in>). The bidders are required to submit soft copies of their bids electronically on the CPP Portal, using valid Digital Signature Certificates. The instructions given below are meant to assist the bidders in registering on the CPP Portal, prepare their bids in accordance with the requirements and submit their bids online on the CPP Portal.

More information useful for submitting online bids on the CPP Portal may be obtained at:

<https://eprocure.gov.in/eprocure/app>

**REGISTRATION:**

1. Bidders are required to enroll on the e-Procurement module of the Central Public Procurement Portal (URL: <https://eprocure.gov.in/eprocure/app>) by clicking on the link "Click here to Enroll" on the CPP Portal is free of charge.
2. As part of the enrolment process, the bidders will be required to choose a unique username and assign a password for their accounts.
3. Bidders are advised to register their valid email address and mobile numbers as part of the registration process. These would be used for any communication from the CPP Portal.
4. Upon enrolment, the bidders will be required to register their valid Digital Signature Certificate (Class II or Class III Certificates with signing key usage) issued by any Certifying Authority recognized by CCA India (e.g. Sify / TCS / nCode / eMudhra etc.), with their profile.
5. Only one valid DSC should be registered by a bidder. Please note that the bidders are responsible to ensure that they do not lend their DSC's to others which may lead to misuse.
6. Bidder then logs in to the site through the secured log-in by entering their user ID / password and the password of the DSC / e-Token.

**SEARCHING FOR TENDER DOCUMENTS**

1. There are various search options built in the CPP Portal, to facilitate bidders to search active tenders by several parameters. These parameters could include Tender ID, organization name, location, date, value, etc. There is also an option of advanced search for tenders, wherein the bidders may combine a number of search parameters such as organization name, form of contract, location, date, other keywords etc. to search for a tender published on the CPP Portal.
2. Once the bidders have selected the tenders they are interested in, they may download the required documents / tender schedules. These tenders can be moved to the respective, "My Tenders" folder. This would enable the CPP Portal to intimate the bidders through SMS / e-mail in case there is any corrigendum issued to the tender document.
3. The bidder should make a note of the unique Tender ID assigned to each tender, in case they want to obtain any clarification / help from the Helpdesk.

## **PREPARATION OF BIDS**

1. Bidder should take into account any corrigendum published on the tender document before submitting their bids.
2. Please go through the tender advertisement and the tender document carefully to understand the documents required to be submitted as part of the bid. Please note the number of covers in which the bid documents have to be submitted, the number of documents - including the names and content of each of the document that need to be submitted. Any deviations from these may lead to rejection of the bid.
3. Bidder, in advance, should get ready the bid documents to be submitted as indicated in the tender document / schedule and generally, they can be in PDF / XLS / RAR / DWF formats. Bid documents may be scanned with 100 dpi with black and white option.
4. To avoid the time and effort required in uploading the same set of standard documents which are required to be submitted as a part of every bid, a provision of uploading such standard documents (e.g. PAN card copy, annual reports, auditor certificates etc.) has been provided to the bidders. Bidders can use "My Space" area available to them to upload such documents. These documents may be directly submitted from the "My Space" area while submitting a bid, and need not be uploaded again and again. This will lead to a reduction in the time required for bid submission process.

## **SUBMISSION OF BIDS**

1. Bidder should login to the site well in advance for bid submission so that he/she upload the bid in time i.e. on or before the bid submission time. Bidder will be responsible for any delay due to other issues.
2. The bidder has to digitally sign and upload the required bid documents one by one as indicated in the tender document.
3. The Bidder has to select the payment option as "Offline" to pay the EMD as applicable and enter details of the instrument.
4. The Bidder should prepare the EMD as per instructions specified in the tender document. The Original should be posted /couriered/ given in person to the concerned official, latest by the last date of bid submission or as specified in the tender documents. The details of the DD/any other accepted instrument physically sent, should tally with the details available in the scanned copy and the data entered during bid submission time. Otherwise the uploaded bid will be rejected.
5. A standard BOQ format has been provided with the tender document to be filled by all the bidders. Bidders are requested to note that they should necessarily submit their financial bid in the format provided and no other format is acceptable. The bidders are required to download the BOQ file, open it and complete the white coloured (unprotected cells with their respective financial quotes and other details (such as the name of the bidder). No other details should be changed. Once the details have been completed, the bidder should save it and submit it online, without changing the file name. If the BOQ file found to be modified by the bidder, the bid will be rejected.

6. The server time (which is displayed on the bidders' dashboard) will be considered as the standard time for referencing the deadlines for submission of the bids by the bidders, opening of bids etc. The bidders should follow this time during bid submission.
7. All the documents being submitted by the bidders would be encrypted using PKI encryption techniques to ensure the secrecy of the data. The data entered cannot be viewed by unauthorized persons until the time of bid opening. The confidentiality of the bids are maintained using the secured Socket Layer 128 bit encryption technology. Data storage encryption of sensitive fields is done.
8. The uploaded tender documents must become readable only after the tender opening by the authorized bid openers.
9. Upon the successful and timely submission of bids *i.e.* after Clicking "Freeze Bid Submission" in the portal), the portal will give a successful bid submission message & a bid summary will be displayed with the bid no. and the date & time of submission of the bid with all other relevant details.
10. Kindly add scanned PDF of all relevant documents in a single PDF file of compliance sheet.

### **ASSISTANCE TO BIDDERS**

1. Any queries relating to the tender document and the terms and conditions contained therein should be addressed to the Tender Inviting Authority or the relevant contact person indicated in the tender.
2. Any queries relating to the process of online bid submission or queries relating to CPP Portal in general may be directed to the 24x7 CPP Portal Helpdesk. The contact number for the helpdesk is 1204200462

### **General Instructions to the Bidders**

1. The tenders will be received online through portal <https://eprocure.gov.in/eprocure/app>. In the Technical Bids, the bidders are required to upload all the documents in pdf format.
2. Possession of a Valid Class II / III Digital Signature Certificate (DSC) in the form of smart card / e-token in the company's name is a prerequisite for registration and participating in the bid submission activities through <https://eprocure.gov.in/eprocure/app>. Digital Signature Certificates can be obtained from the authorized certifying agencies, details of which are available in the website <https://eprocure.gov.in/eprocure/app> under the link "Information about DSC".
3. Tenderer are advised to follow the instructions provided in the "Instructions to the Tenderer" for the e-submission of the bids online through the Central Public Procurement Portal for e- Procurement at <https://eprocure.gov.in/eprocure/app>

KIND ATTENTION: FOR TAKING ASSISTANCE, IF ANY, VISIT  
CPP Portal website: [www.eprocure.gov.in](http://www.eprocure.gov.in)

**FINANCIAL BID**

**Name of work:** Construction of Polyhouse with 04 nos. of platform near playground at Garacharma Farm.

**Size of Polyhouse:** 10m (L) x 10m (B) x 2.6m (H)

**Scheduled of Quantities**

Sl. No.	Description of Work	Qty	Unit	Rate	Amount
1.	Earth work in surface excavation not exceeding 30 cm in depth but exceeding 1.5 m in width as well as 10 sqm on plan including getting out and disposal of excavated earth upto 50 m and lift upto 1.5 m, as directed by Engineer-in- Charge: All kinds of soil	300.00	Sqm		
2.	Earth work in excavation by mechanical means (Hydraulic excavator) / manual means in foundation trenches or drains (not exceeding 1.5 m in width or 10 sqm on plan), including dressing of sides and ramming of bottoms, lift upto 1.5 m, including getting out the excavated soil and disposal of surplus excavated soil as directed, within a lead of 50 m. All kinds of soil.	4.50	Cum		
3.	Providing and laying in position cement concrete of specified grade excluding the cost of centering and shuttering - All work up to plinth level :				
3.1	1:4:8 (1 Cement : 4 coarse sand (zone-III) derived from natural sources : 8 graded stone aggregate 40 mm nominal size derived from natural sources)	1.50	Cum		
3.2	1:3:6 (1 Cement : 3 coarse sand (zone-III) derived from natural sources : 6 graded stone aggregate 20 mm nominal size derived from natural sources)	2.75	Cum		
3.3	1:2:4 (1 Cement : 2 coarse sand (zone-III) derived from natural sources : 4 graded stone aggregate 40 mm nominal size derived from natural sources)	2.41	Cum		
4.	Centering and shuttering including strutting, propping etc. and removal of form work for :				
4.1	Retaining walls, return walls, walls (any thickness) including attached pilasters, buttresses, plinth and string courses fillets, kerbs and steps, column base, short column, etc.	22.50	Sqm		
5.	Providing and fixing hand rail of approved size by welding etc. to steel ladder railing, balcony railing, staircase railing and similar works, including applying priming coat of approved steel primer.				
5.1	G.I. pipes (G.I. square tubes, round pipes, flats, square bars, angles, etc.)	2,500.00	Kg		
6.	Providing and fixing anodised aluminium	200.00	Kg		



	grill/mesh of approved design/pattern, with approved standard section and cutting to required size and fixed to the platform frame with C.P. brass/ stainless steel screws @ 150-200 mm centre to centre, all complete as per requirement and direction of Engineer-in-charge. (Only weight of grill/mesh to be measured for payment).				
7.	Cement concrete hollow Block masonry with cement concrete hollow block of size 400x200x150mm laid in cement mortar 1:6 (1 cement : 6 pulverised sand), and as directed by the Incharge Estate section/Engineer-in-charge. (upto a height of 0.6m above PCC)	3.50	Cum		
8.	12 mm cement plaster of mix :				
8.1	1:6 (1 cement: 6 fine sand)	65.00	Sqm		
9.	12 mm cement plaster finished with a floating coat of neat cement of mix :				
9.1	1:3 (1 cement: 3 fine sand)	5.50	Sqm		
10.	Finishing walls with Acrylic Smooth exterior paint of required shade : New work (Two or more coat applied @ 1.67 ltr/10 sqm over and including priming coat of exterior primer applied @ 2.20 kg/10 sqm)	65.00	Sqm		
11.	Painting with aluminium paint of approved brand and manufacture to give an even shade. Two or more coats on new work	110.00	Sqm		
12.	Providing and fixing aluminium gutter (600mm girth) made of aluminium sheet 24/26 gauge thickness fastened to 40x6 GI flat brackets with GI nut bolts and washers all complete. (The rate is inclusive of providing & welding of 40x6 GI flat to the purlin @ 75-80cm spacing)	10.50	Metre		
13.	Providing and fixing of 40mesh UV stabilized nylon insect proof net, wall and gable side of the polyhouse structure all complete.	105.00	Sqm		
14.	Supply of aluminium channel and zig zag spring and fixing it with self drilling screw for fixing 200 GSM UV film all complete as per the direction of Incharge Estate Section. Additional layer of zig zag spring shall be provided wherever two layers of membrane are provided if required. <b>The rate shall also include any additional layer of zig zag spring required for fixing of multiple layers of membranes such as UV film and agro shade net on roof or IP net and UV film on walls. The measurement shall be taken only once for payment.</b>	210.00	Metre		
15.	Providing and fixing 200 GSM, 5 layered, drip locked U.V. film with anti flapping strip over the steel structure (along wall) as curtain with movement along vertical direction i.e up and down direction all complete as per the direction of Incharge Estate Section.	85.00	Sqm		
16.	Providing and fixing 200 GSM, 5 layered, drip locked U.V. film over the steel structure (roof, door portion and gable portion) all complete as per the direction of Incharge Estate Section.	142.00	Sqm		
17.	Providing and fixing agro shade net (50%) over the steel structure (roof) all complete as per the direction of Incharge Estate Section.	110.00	Sqm		

18.	Providing and placing on terrace (at all floor levels) polyethylene water storage tank, IS : 12701 marked, with cover and suitable locking arrangement and making necessary holes for inlet, outlet and overflow pipes but without fittings and the base support for tank.	1000.00	Per litre		
19.	Supplying and installing single phase self priming 1 HP pumpset, 220 volts, 50Hz with head capacity upto 20 m, suction x delivery 25x25mm, including providing electrical connection, etc., all complete.	1.00	Each		
20.	Supply and installation of HDPE superflow screen filter in the pumping line having discharge capacity of 12 cum/hr.	1.00	Nos.		
21.	Providing and laying of 25 mm dia PVC pipe in the inlet and outlet end of pumpset including connecting the delivery end of water tank including the cost of fittings such as MTA, FTA, elbow, bend, socket, paste, reducer, tee, and testing of joints, all complete.	20.00	Metre		
22.	Providing and fixing of PVC valve of 25mm dia with required paste in pumping line of approved quality and make.	2.00	Nos.		
23.	Supply and installation of 16mm LDPE lateral pipe with all fitting and accessories for fixing fogger assy including providing GI wire of required gauge for fastening the LDPE pipe to the truss/overhead framework.	70.00	Metre		
24.	Supply and installation of PVC fogger assembly of approved make, required discharge, etc. all complete.	48.00	Nos.		
25.	Supply and fixing of hand operated crank mechanism for moving up and down the plastic curtains covering each side of polyhouse spanning upto 10m with required clamps, guide pipes, base pipes, lever, etc. including the cost of cutting of earth, erection and concreting of base of guide pipe post as required, all complete.	4.00	Set		
26.	Supply and fixing of Electric control panel with MCB, relay, contractors, 3-way switch, voltmeter, RYB indicator with temperature and relative humidity sensor to operate fogging/misting system in auto mode with minimum 2 years warranty of approved make and quality.	1.00	Set		
27.	Supply and fixing of Digital data loggers of approved make and quality with the following features: LCD with time and date display, with freely selectable measurement cycle from 1 second to 24 hours of relative humidity (RH) and temperature, data transfer software and accessories for transfer of collected data to PC using USB, with analysis software to view graph for logged data. With measurement range: 0 to 100% (RH) and 0 to 70 °C (temperature), resolution: 0.1% (RH) and 0.1 °C (temperature) and accuracy of 3% (RH) and 1 °C (temperature). With memory to record minimum 30,000 values.	2.00	Set		
28.	Supply and fixing of Lux meter of approved make and quality with the following features: a portable model for measurement of all types of visible lights including LED white light. With	1.00	Set		

	Silicon photodiode sensor with filter. Measuring Range from 40 to 4,00,000 Lux , with accuracy of 3-6%. Provided with minimum 1.5 m wire for light sensor, with overload and low battery indication. With sampling rate of minimum 2 times per second for digital display. With accessories such as battery, user Manual, carrying case etc. With minimum 1 year warranty.				
29.	Charges for covering of pumpset with iron brackets and roof sheet available with Estate Section with required screws, fasteners, etc. (iron bracket and roof sheet shall be provided by the Institute)	1 Job	LS		
<b>Total</b>					

NAME OF WORK : CONSTRUCTION OF A POLY HOUSE

2202743/2024/Estate-CIARI

NEAR PLAYGROUND AT GARACHARMA FARM

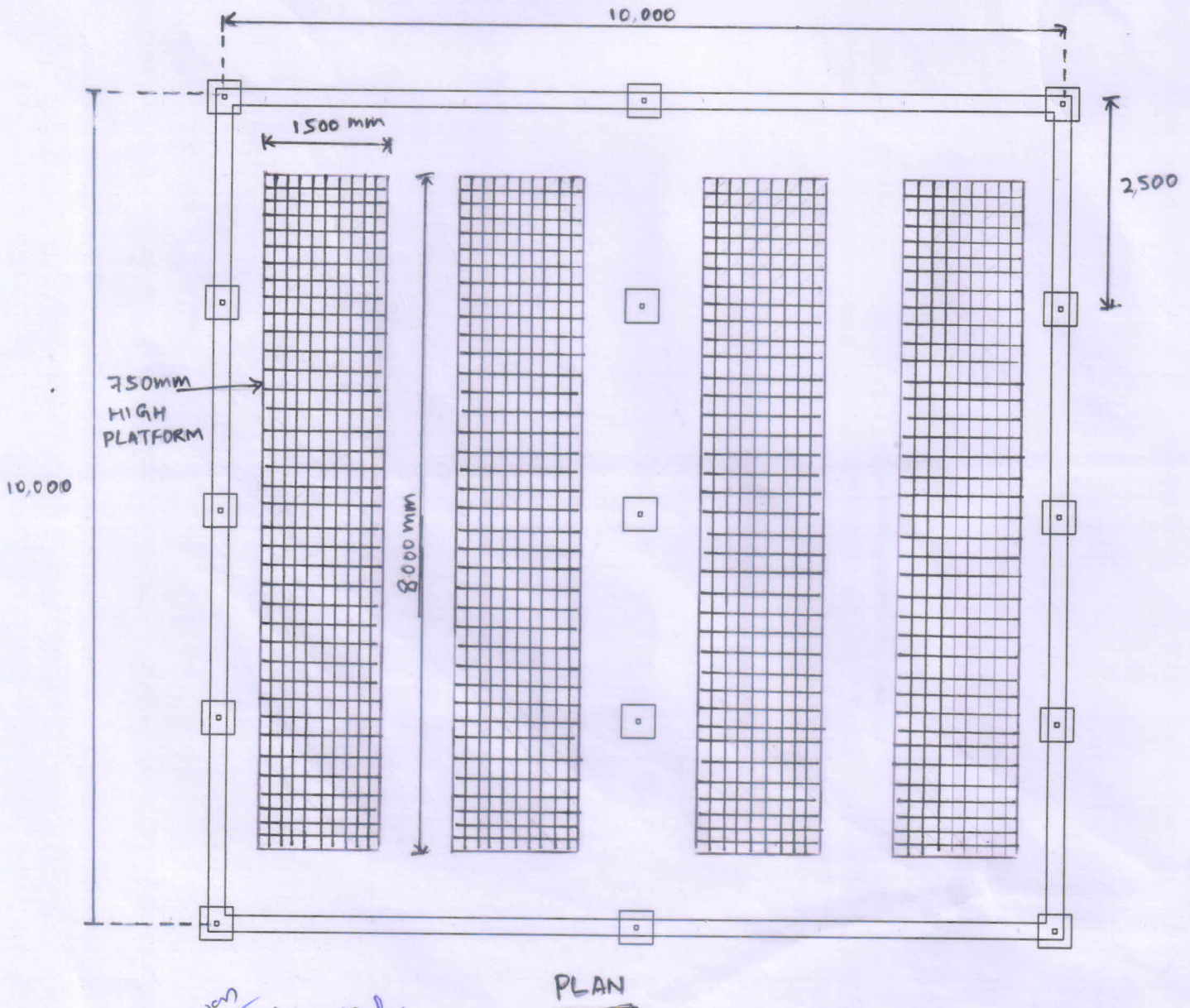
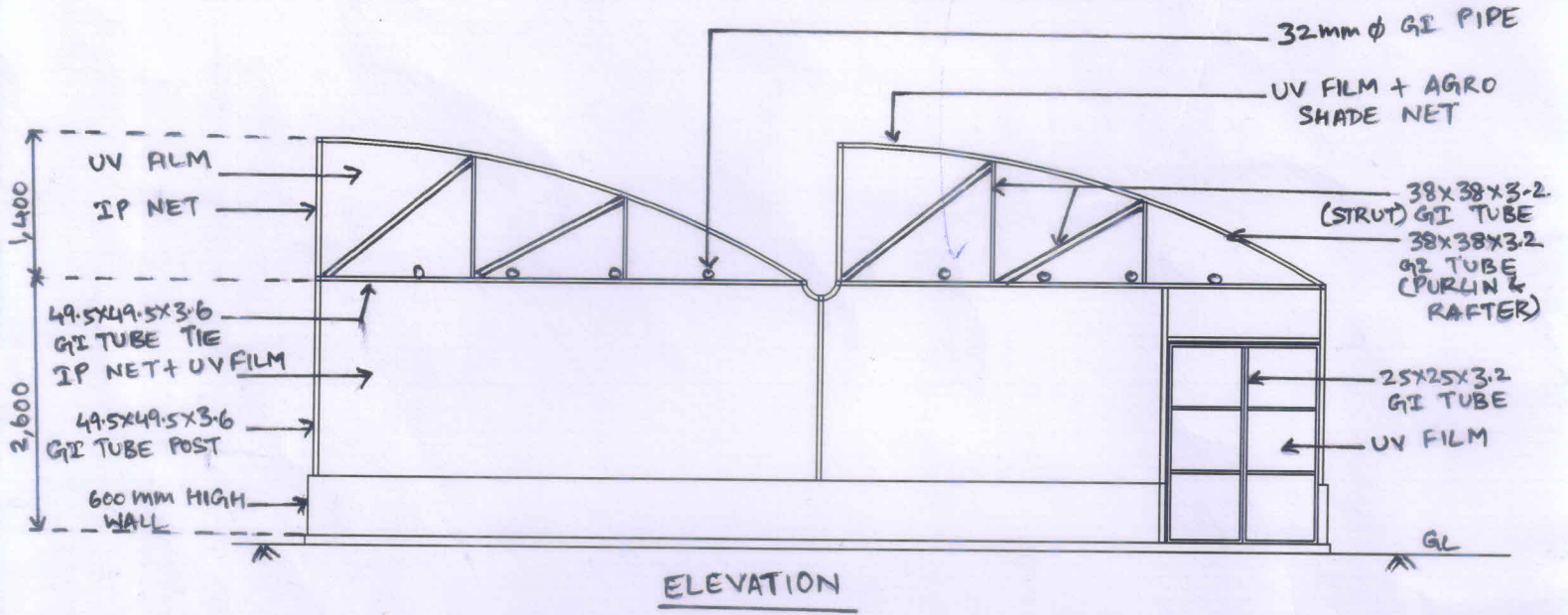

*Signature*  
19/8/24

*Signature*  
19/8/24

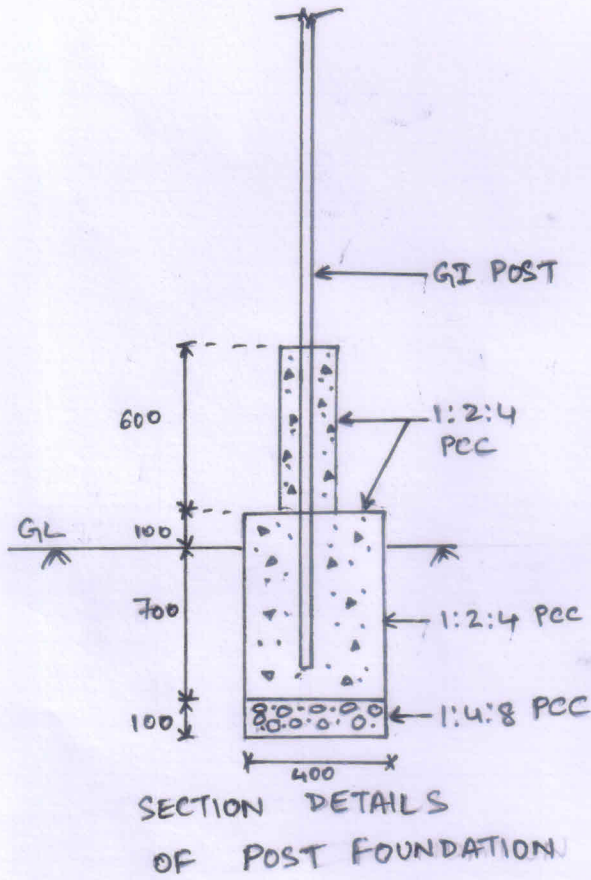

*Handwritten signature*  
19/8/24

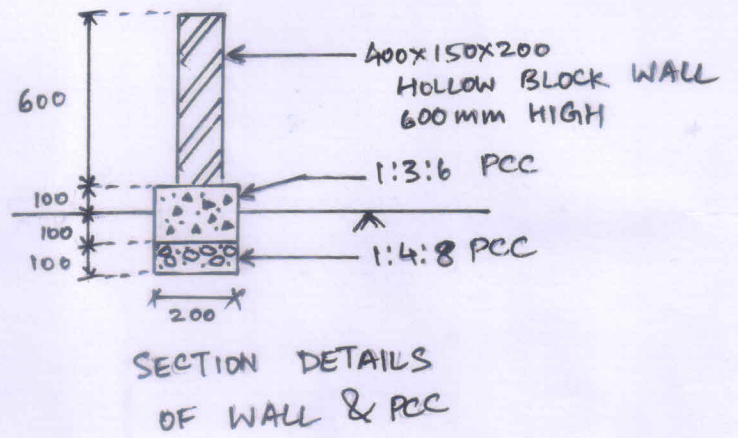

*Handwritten signature*  
19/8/24

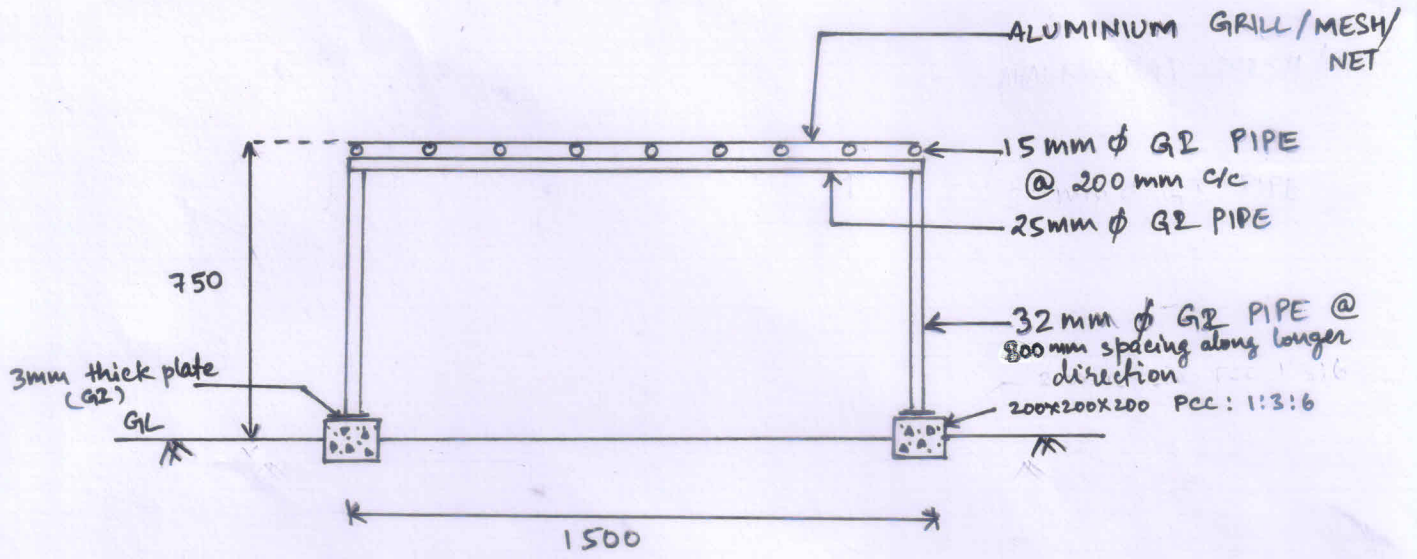

DETAILS OF PLATFORM (8m x 1.5m x 0.75m - 4 nos.)

*Prady*  
19/8/2024

*M. Kumar*  
19/8/24